

# Meline Series (S30C / S50C)

***Column Portable PA System***

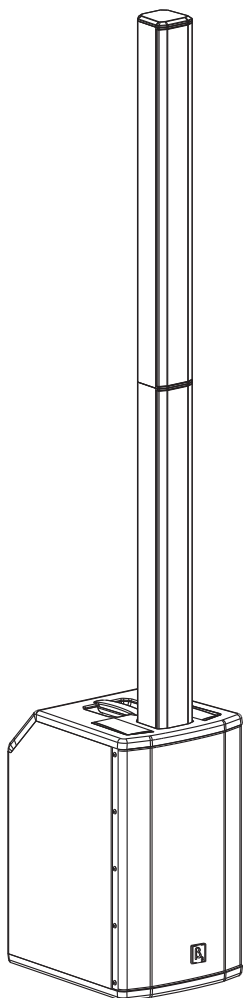

**Beta Three**



Owner's  
Manual



---

# Contents

Section 1: Important Safety Instructions.....	05
· GENERAL WARNINGS.....	05
· POWER & GROUNDING.....	05
· VENTILATION & ENVIRONMENT.....	05
· LIFTING & TRANSPORT.....	06
· ASSEMBLY & STACKING (GROUND-STACKED USE).....	06
· CABLING & CONNECTORS.....	06
· SOUND EXPOSURE.....	06
· Bluetooth® / RF.....	07
· MAINTENANCE & SERVICE.....	07
· SYMBOLS & MARKINGS.....	07
· MANUFACTURER RESPONSIBILITY DISCLAIMER.....	08
Section 2: Overview.....	08
Section 3: Key Features & Highlights.....	09
· PERFORMANCE & SOUND.....	09
· MIXER & CONNECTIVITY.....	09
· BUILD & DESIGN.....	09
Section 4: Package Contents.....	10
Section 5: System Setup.....	11
· SYSTEM INSTALLATION.....	11
· CONNECTIONS & CONTROLS.....	12
· CONNECTING POWER.....	14
· GAIN STRUCTURE (SINGLE UNIT).....	14
· CONNECTING SOURCES.....	15
· Bluetooth® AUDIO.....	15
· PRE-SHOW CHECKS.....	16
Section 6: System Configurations.....	17
· ELEVATED SURFACE (performance-oriented).....	17
· GENERAL-PURPOSE PA (speech-oriented).....	18
· EXTERNAL MIXER (mono feed).....	19

---

---

# Contents

- DUAL MAIN / DAISY CHAIN (XLR Link).....20
- TWS STEREO (Bluetooth® Wireless).....21
- Section 7: Care & Maintenance.....23
- Section 8: Troubleshooting.....25
- Section 9: Specifications.....27

---

# Section 1: Important Safety Instructions

Read and keep these instructions. Operate indoors on a dry, stable surface. Connect protective earth. Do not expose to rain or high moisture. Follow local electrical codes.

## GENERAL WARNINGS

1. **No liquids:** Do not expose to rain, spray, or standing water. Keep drinks and containers off the unit.
2. **Stable base:** Place on a flat, load-bearing surface. No wobble; no tilt.
3. **Children/public:** Prevent access to controls and cabling in public areas.
4. **Disconnect:** Unplug the IEC inlet during lightning storms or long inactivity.
5. **No user service:** Do not open the enclosure. Risk of electric shock.

## POWER & GROUNDING

1. **Rated voltage only:** Match mains to the label on the product.
2. **Protective earth:** Use a grounded outlet. Do not defeat earth with cheater plugs.
3. **Circuit capacity:** One loudspeaker per 10 A circuit (typical). Derate when linking multiple units.
4. **Residual-current protection (RCD/GFCI) protection:** Required for outdoor or temporary power; test before each event.
5. **Inrush:** Power up sources and mixers first, loudspeakers last. Power down in reverse order.

## VENTILATION & ENVIRONMENT

1. **Free airflow:** Keep all vents clear ( $\geq 100$  mm). Do not cover with fabric or cases.
2. **Temperature:** Operate 0–35 °C. Thermal mute may occur above this range; allow cooling.
3. **Sun/heat:** Keep away from heaters and direct sun.
4. **Condensation:** After transport in cold weather, wait until moisture evaporates before power-on.
5. **Outdoor use:** Weather protection required. The product is not rainproof.

---

## LIFTING & TRANSPORT

1. **Separate modules:** Move sub and column sections unassembled.
2. **Team lift:** Use two persons when handling stairs or uneven ground.
3. **Handles:** Use built-in handles only. They are for carrying, not suspension.
4. **Carts:** Strap the cabinet to a rated cart. No stacked transport without restraints.

## ASSEMBLY & STACKING (GROUND-STACKED USE)

1. **Sub placement:** Front grille to audience. No obstruction in front ports/vents.
2. **Column fit:** Insert extension fully; seat top column until detent visible; pull-test.
3. **Rigidity check:** Push from four sides—no play. If play exists, re-seat and retest.
4. **Cable relief:** Route signal and IEC away from walk paths; provide strain relief at the panel.

## CABLING & CONNECTORS

1. **Balanced lines:** Use balanced XLR for long runs. Keep signal away from AC cables.
2. **Linking:** Use LINK OUT → MAIN IN only. Max 16 linked systems (design limit).
3. **Instrument vs line:** Guitar/bass to INSTRUMENT (Hi-Z). Mixers/keyboards to LINE (¼" TRS).
4. **Mic inputs:** Use XLR. Phantom power may be active; verify before connecting ribbon mics.
5. **Strain relief:** Loop and tie all cables; no tension on panel connectors.

## SOUND EXPOSURE

1. **Hearing risk:** Continuous exposure >90 dB SPL can cause damage.
2. **Limit testing:** Wear hearing protection during system checks and when operating near the array.
3. **Feedback control:** Keep microphones behind the column axis. Use Speech/Concert modes as appropriate.

---

## Bluetooth® / RF

1. **Pairing:** Press & hold 4-second to pair.
2. **Region use:** Operate wireless features only where permitted.
3. **Separation:** Keep  $\geq 20$  cm from RF-sensitive medical devices.

## MAINTENANCE & SERVICE

1. **Before each use:** Inspect enclosure, grille, and fasteners. No cracks; no loose hardware.
2. **Connectors:** Inspect XLR/TRS sockets. No bent pins; latch engages; pull-test the plug.
3. **Column joint:** Verify column sections fully seated. Detent visible; pull-test.
4. **Cables:** Inspect for cuts/kinks. Strain relief intact.
5. **Service:** If liquid ingress, smoke, burning odour, or impact damage occurs — disconnect from mains immediately and refer to service.

## SYMBOLS & MARKINGS



**CAUTION - RISK OF ELECTRIC SHOCK: Do not remove the cover. No user-service able parts inside.** Servicing should be performed by qualified personnel only.

**CAUTION – REFER TO MANUAL: Read all safety and service information before use.**

---

## MANUFACTURER RESPONSIBILITY DISCLAIMER

1. BETA THREE is not responsible for damage, malfunction, or injury resulting from improper installation, operation, or maintenance of this product.
2. Use this equipment only as described in the accompanying documentation. Unauthorized modifications, repairs, or the use of accessories not specified by the manufacturer may void the warranty and compromise safety compliance.
3. The operator is responsible for maintaining safe sound pressure levels, stable mounting, and adherence to all applicable electrical and mechanical safety standards in their region.

## Section 2: Overview

### Thank you for purchasing the BETA THREE Meline Series.

Meline is a compact column PA with two models—S30C (10" sub) and S50C (12" sub)—using a column of 4×3" mids + 0.75" HF driven by Class-D amplification (1,550 W peak).

DSP offers Concert / Club / Speech voicings with wide horizontal dispersion, while the rear panel provides a 3-channel mixer (up to 7 inputs), Bluetooth® streaming/stereo link, and +4 dBu balanced XLR Main In / Link Out for linking up to 16 units.

The hybrid wood LF cabinet and ABS column with tool-less stack support fast, reliable setup for professional reinforcement.

---

## Section 3: Key Features & Highlights

### PERFORMANCE & SOUND

- **Column transducers:** 4 × 3" neodymium mids + 0.75" exit neodymium HF for vocal clarity to 20 kHz.
- **Output capability:** S30C 124.5 dB peak / 118.5 dB cont.; S50C 126 dB peak / 120 dB cont. (1 m).
- **DSP voicings:** Concert / Club / Speech presets; fixed 90 Hz HPF on Ch.1 for stage rumble control.
- **Amplification:** 1550 W peak total (1250 W LF + 300 W MF/HF). Thermal & over-exursion protection.

### MIXER & CONNECTIVITY

- **On-board mixer:** 3-channel / 7-input layout (Ch.1 Mic/Instrument; Ch.2 Mic/Line; Ch.3 3.5 mm AUX; Bluetooth®; XLR Main In). Per-channel Clip and Master Activity LEDs.
- **Linking:** Balanced +4 dBu XLR Main In / Link Out; daisy-chain up to 16 columns for larger rooms. Wireless stereo pairing for dual-column setups.

### BUILD & DESIGN

- **Enclosure:** Wooden LF cabinet for rigidity; ABS column for low mass; powder-coated full-length metal grille.
- **Modular stack:** Tool-less spacer + array for quick assembly and optimal acoustic height.

---

## Section 4: Package Contents

- Powered subwoofer module (S30C 10" or S50C 12")
- Column extension (spacer)
- Column top (array section with  $4 \times 3'' + \text{HF}$ )
- IEC mains power cord
- Owner's manual

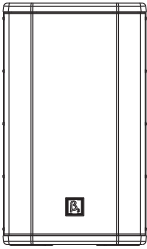

Powered subwoofer module  
(S30C 10" or S50C 12")



Column extension  
(spacer)



Column top  
(array section with  $4 \times 3'' + \text{HF}$ )



IEC mains power cord

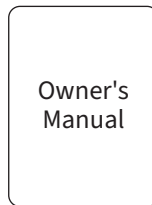

Owner's Manual

---

## Section 5: System Setup

### SYSTEM INSTALLATION

- **Place** the subwoofer on level, load-bearing ground; **front grille faces audience.**
- **Insert** the column **extension** fully into the sub; **detent visible; pull-test.**
- **Seat** the **top column** onto the extension until latched; **no wobble** when pushed from four sides.
- **Route** AC and signal separately; **strain-relief** at panel; no trip hazards.
- **Connect** sources to the rear I/O.
- **Power** the unit **ON** (sources → speaker sequence); status LED illuminates.
- **Select Mode** (Concert / Club / Speech) for the task.
- **Raise** level from **MIN** using **MASTER** and **SUB** to required SPL.

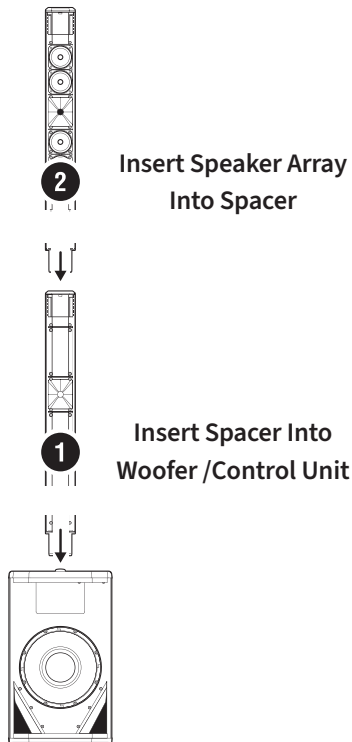

---

## CONNECTIONS & CONTROLS

### Controls (upper section)

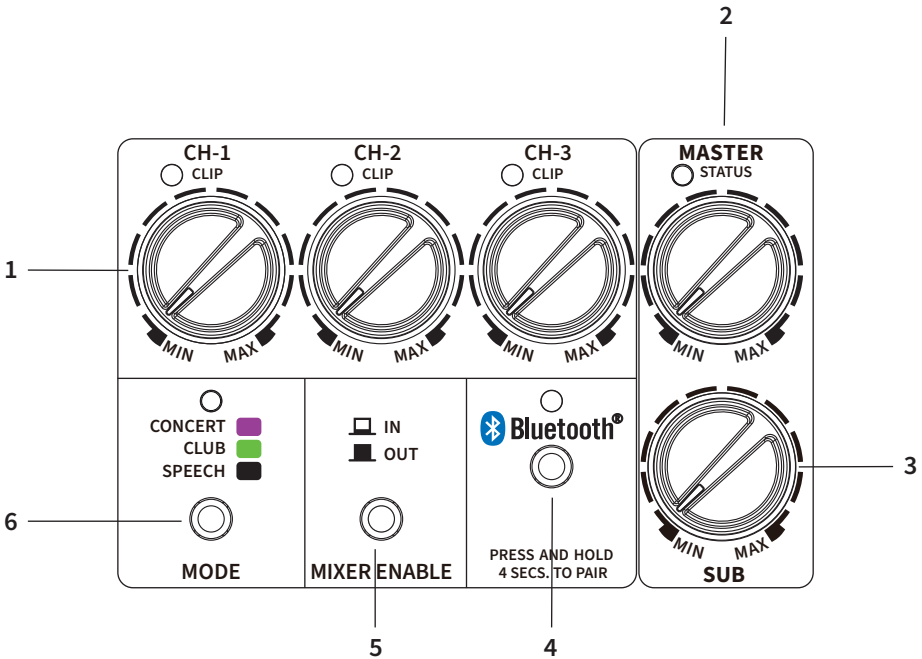

1. **CH-1 / CH-2 / CH-3 (Level):** Set per-channel gain; avoid CLIP LED on peaks.
2. **MASTER:** Set overall system output after channel trims.
3. **SUB:** Balance LF relative to column; reduce for speech.
4. **Bluetooth® (Pair):** Press & hold ~4 s to enter pairing (LED flashes).
5. **MIXER ENABLE (IN/OUT):** IN = use on-board mixer; OUT = bypass channels, take MAIN IN.
6. **MODE:** Concert / Club / Speech DSP voicings.

---

## I/O (lower section)

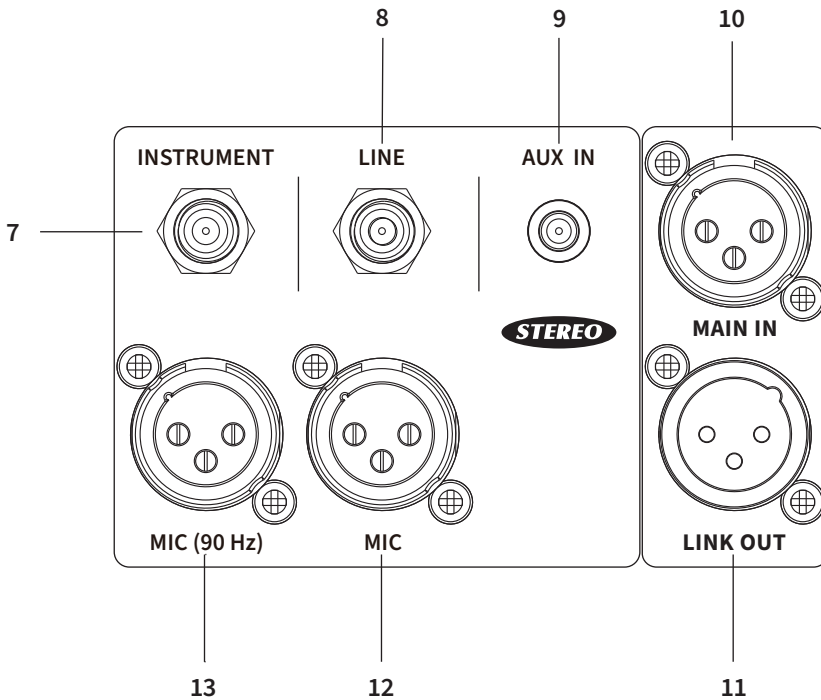

7. **INSTRUMENT** (1/4" TS, Hi-Z): Guitar/bass direct; not for line sources.
8. **LINE** (1/4" TRS): Line-level (balanced TRS or unbalanced TS) from keyboards/players/mixers.
9. **AUX IN** (3.5 mm): Stereo consumer device (summed to mono).
10. **MAIN IN** (XLR, +4 dBu balanced): External mixer/program feed.
11. **LINK OUT** (XLR, balanced): Program to next powered column (daisy-chain).
12. **MIC** (XLR): Second microphone input.
13. **MIC (90 Hz)** (XLR): Mic with fixed 90 Hz high-pass for rumble control.

---

## CONNECTING POWER

- **Supply rating:** 100–240 V~, 50/60 Hz, grounded outlet. Use the supplied IEC lead.
- **Circuit loading:** One loudspeaker per 10 A circuit is typical; avoid sharing with lighting dimmers.
- **Cable routing:** Keep AC and audio on separate runs; no coils or pinch points; apply strain-relief at inlet.
- **Sequence (power-up):** Sources ON → external mixer ON → loudspeaker ON.  
**Sequence (power-down):** Loudspeaker OFF → mixer OFF → sources OFF.
- **Abnormal events:** If breaker trips or unit mutes thermally — power down, inspect cabling/ventilation, allow cool-down, then restore.

## GAIN STRUCTURE (SINGLE UNIT)

- **Start:** Set MASTER and SUB to MIN; channel knobs to MIN.
- **Source:** Set player/keyboard/interface to nominal ( $\approx 75\%$  or mixer 0 dB).
- **Channel trims:** Raise CH-1/2/3 until the CLIP LED just does not light on programme peaks.
- **Master:** Raise MASTER to the required SPL.
- **LF balance:** Trim SUB for programme (reduce for Speech, add for Club).
- **Mixer path:** With MIXER ENABLE = IN, channels + Bluetooth feed the system. With MIXER ENABLE = OUT, channels are bypassed; programme comes from MAIN IN.
- **Check:** If distortion occurs with no CLIP LEDs, lower the source device level (hot input).

---

## CONNECTING SOURCES

1. Microphone (wired/wireless) → MIC (XLR)
  - Use MIC (90 Hz) to reduce handling/footfall rumble.
  - If phantom power is present, avoid ribbon mics; power receivers from mains, not phantom.
2. Guitar/Bass (passive pickups) → INSTRUMENT (1/4" TS, Hi-Z)
  - Do not plug instruments into LINE; tone loss or noise may occur.
3. Keyboard / Player / Small mixer → LINE (1/4" TRS)
  - Accepts balanced TRS or unbalanced TS at line level.
4. Phone / Tablet / Laptop (analogue) → AUX IN (3.5 mm TRS)
  - Stereo is internally summed to mono.
5. External mixer / Console → MAIN IN (XLR, +4 dBu balanced)
  - Set MIXER ENABLE = OUT; keep CH-1/2/3 at MIN.
6. Link to additional units → LINK OUT (XLR) to next speaker's MAIN IN
  - Plan up to 16 linked units; balance each with its local MASTER/SUB.

## Bluetooth® AUDIO

- **Pairing:** Press & hold the Bluetooth button for ~4 s → LED flashes → select the speaker on your device.
- **Level:** Set device volume ≈ 75 %; finish gain with channel /master.
- **Stereo (TWS):** Use wireless Primary/Secondary link for L/R (see Section 6); place columns symmetrically.
- **Re-pair/Clear:** Hold the button again to re-enter pairing; remove the device in your OS if needed.

**NOTE:** Bluetooth adds latency; use wired I/O for live instrument monitoring.

---

## PRE-SHOW CHECKS

- **Mechanical:** Column joints latched; no wobble; push from four sides; detent visible; pull-test.
- **Cabling:** IEC and XLR fully seated; latches engage; no cuts/kinks; strain-relief applied; walkways clear.
- **Panel:** No bent XLR pins; channel CLIP LEDs off at idle; STATUS LED normal.
- **Coverage:** Column upright; top above audience head height; microphones behind the column axis.
- **Power:** RCD/GFCI tested; dedicated circuit available; sequence confirmed (sources → speaker).

---

## Section 6: System Configurations

### ELEVATED SURFACE (performance-oriented)

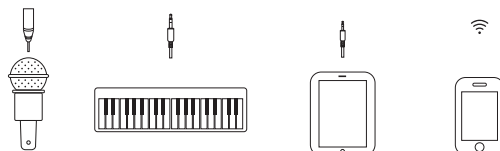
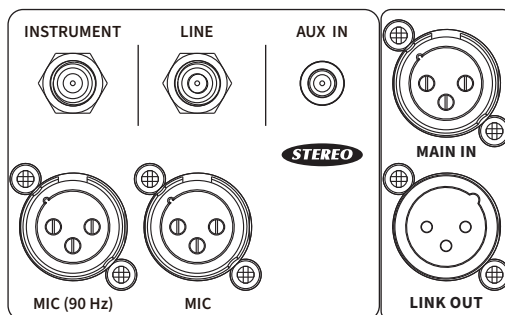

- **Place** the subwoofer on a firm riser/stage; full surface contact; no rocking.
- **Aim** the column vertically; the **top module must be above audience head height** for correct projection.
- **Select Mode = Concert** (live performance) or **Club** (music playback).
- **Route AC** and audio separately; avoid coiling AC with signal; keep walk paths clear.
- **Typical Inputs:** vocal mic (**MIC XLR**), guitar/bass (**INSTRUMENT 1/4"**), keyboard or line source (**LINE 1/4" TRS**), AUX playback (**3.5 mm**), or **Bluetooth®** audio.
- **Mic use:** Performers with microphones **must stand behind the column axis** to maintain stable gain-before-feedback.

---

## GENERAL-PURPOSE PA (speech-oriented)

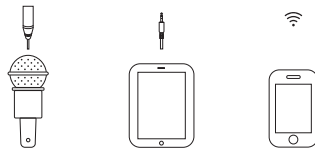
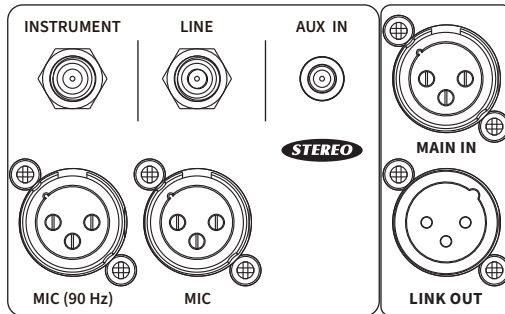
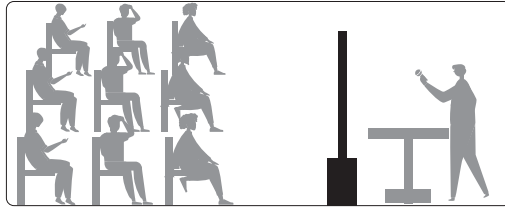

- **Placement:** Ground-stacked or elevated on a riser; column vertical; top module above head height.
  - **Mode: Speech** — optimised for vocal clarity, intelligibility, and controlled LF.
  - **Source Options:**
    - Local 3-channel mixer (**CH-1/2/3 + Bluetooth®**).
    - External mixer → **MAIN IN (XLR) (MIXER ENABLE = OUT)**.
  - **Gain:** Trim channels so **CLIP** LEDs stay off, then raise **MASTER** to working SPL.
  - **SUB Level:** Reduce for voice-only events to improve intelligibility.
  - **Mic Placement:** All microphones **must remain behind the column** to avoid feedback.
  - **Typical Inputs:** MIC XLR, AUX 3.5 mm, Bluetooth®, or MAIN IN XLR from a small mixer.
-

---

## EXTERNAL MIXER (mono feed) – *recommended for bands*

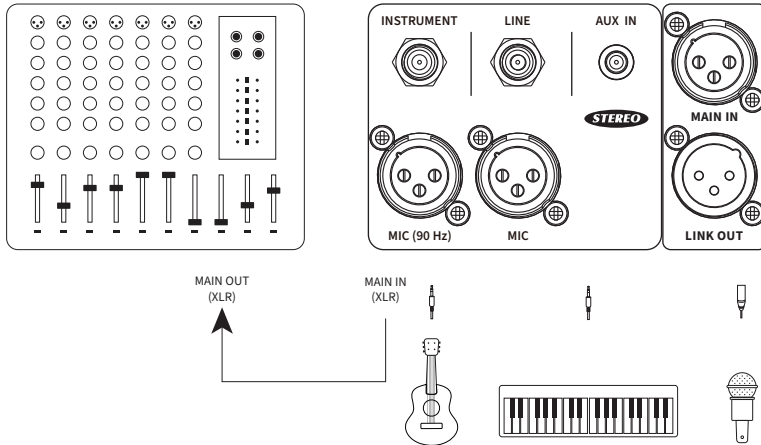

- Route mixer **MAIN OUT (XLR)** → **MAIN IN (XLR, +4 dBu balanced)**.
- Select **MIXER ENABLE = OUT**; keep CH-1/2/3 at **MIN** (local mixer bypassed).
- **Control** programme level at the external mixer; use loudspeaker **MASTER/SUB** for local trim.
- **Link** additional Meline units via **LINK OUT (XLR)** for wider or deeper room coverage.
- **Typical Setup:** External mixer handles all mics, instruments, and playback sources.

---

## DUAL MAIN / DAISY CHAIN (XLR Link)

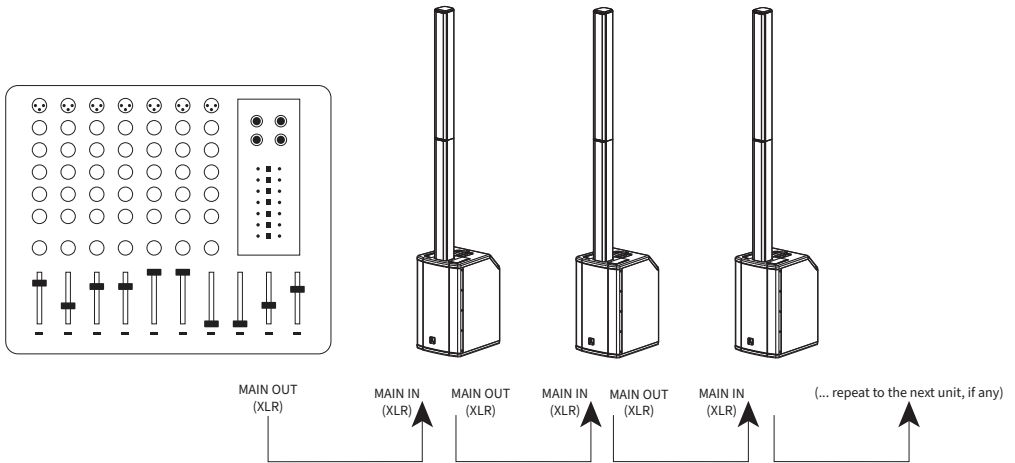

- **Plan** one programme feed replicated to multiple units (up to 16 linked systems).
- **Wire:** **LINK OUT** → **MAIN IN** on the next unit; repeat across the line.
- **Select:** On follower units, set **MIXER ENABLE = OUT** (bypass local channels).
- **Trim:** Use **MASTER/SUB** on each unit to balance zones (near/far, left/right).
- **Verify:** No **CLIP** on any unit; perform a walk-test for level consistency.
- **Power:** Distribute AC across circuits; avoid daisy-chained power strips.
- **Failure mode:** If a mid-chain unit loses power or is disconnected, audio beyond that unit may stop. Repatch **LINK OUT** from the last working unit to restore the chain.
- **Cable Practice:** XLR is balanced — keep audio runs away from AC lines; label link direction.
- **Mixer limit:** In a linked system, set **MIXER ENABLE = IN** on up to three units only. Set all other linked units to **MIXER ENABLE = OUT**.

---

**TWS STEREO (Bluetooth® Wireless)** – *recommended for playback*

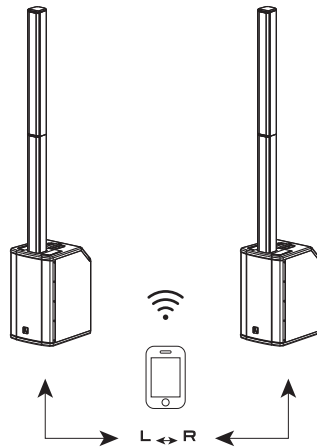

Use this configuration to create a wireless stereo pair using two Meline systems.

1. Power ON the Left unit (Primary).
2. Tap the Bluetooth button once on the Left unit to turn on Bluetooth.
3. Press and hold the Bluetooth button for 4 seconds until the Bluetooth indicator flashes rapidly (pairing mode).
4. On your phone/tablet, open the Bluetooth settings and select 'S30C' (for a Meline S30C) or 'S50C' (for a Meline S50C) from the device list.
5. Play some audio and confirm it is heard from the Left unit (primary).
6. Power ON the Right unit (Secondary).
7. Tap the Bluetooth button once on the Right unit to turn on Bluetooth.
8. Double-tap the Bluetooth button on the Left (Primary) unit.
9. Within a few seconds, double-tap the Bluetooth button on the Right (Secondary) unit.
10. After a short delay, the two units form a TWS stereo pair:
  - Primary = Left channel + device connection
  - Secondary = Right channel (wireless link only)

---

TIP: This setup gives true left/right stereo without signal cables – ideal for cafés, small events, and rehearsals where fast setup is important.

**NOTES:**

- Range: Keep the two Meline units within  $\approx 10$  m line-of-sight; walls and 2.4 GHz congestion can reduce range.
- Device connection: Your phone/tablet connects only to the Primary unit. The Secondary receives audio wirelessly from the Primary.
- Breaking the link: To exit stereo mode, turn Bluetooth off on one or both units (press and hold the Bluetooth button for  $\approx 8$  seconds, or power the unit OFF).

---

## Section 7: Care & Maintenance

### ROUTINE (before each use)

- **Inspect** cabinet and grille: no cracks, loose fasteners, or deformation.
- **Verify** column joints: **detent visible; pull-test**; push from four sides—**no wobble**.
- **Check** connectors: XLR pins straight; latches engage; ¼" jacks grip firmly.
- **Confirm** cabling: no cuts/kinks; correct lengths; strain-relief at panel; walkways clear.
- **Test** controls: CH-1/2/3, **MASTER/SUB, MODE, MIXER ENABLE** move smoothly; no scratch noise.
- **Power on**: status LED normal; no burning smell or abnormal heat.

### PERIODIC (monthly or every 20 shows)

- **Tighten** external hardware: handle screws, feet, panel screws (hand-tight only).
- **Clean** connector contacts: lint-free swab; contact cleaner rated for audio (sparingly).
- **Exercise** jacks/switches: insert/remove 3–5 times to clear oxidation.
- **Review** link kit: test **LINK OUT** → **MAIN IN** continuity with a spare XLR.
- **Log** findings: date, venue, anomalies, corrective action.

### CLEANING

- **Exterior**: dry, soft cloth. Stubborn marks: slightly damp cloth with mild soap; dry immediately.
- **Grille/ports**: vacuum on low; no compressed air into ports.
- **Prohibited**: solvents, alcohol, abrasives, pressure washers.

### TRANSPORT & STORAGE

- **Separate modules**: move sub and columns unassembled.
- **Case** or sleeve recommended: prevent grille dents and connector damage.
- **Position upright**; avoid stacking heavy loads on columns.
- **Environment**: cool, dry, dust-free; 0–35 °C operating, avoid condensation.
- **After** cold transport: acclimatise until moisture evaporates before power-on.

---

## SERVICE

- **Isolate** immediately if liquid ingress, impact, smoke, or odour occurs.
- **Do not open** the enclosure; no user-serviceable parts inside.
- **Refer** to qualified service personnel; attach your maintenance log.

---

## Section 8: Troubleshooting

No.	Issue	Possible Cause / Action
1	No Power	Verify IEC lead and wall outlet. Switch <b>POWER</b> to ON. Check RCD/GFCI or breaker; reset if tripped. Avoid daisy-chained AC strips; try a known-good outlet.
2	No Sound	Set <b>MIXER ENABLE</b> correctly: IN (local mixer) or <b>OUT</b> (MAIN IN path). Raise source/device volume; unmute. Increase channel levels above <b>MIN</b> and then <b>MASTER</b> . Try another input (AUX/LINE/MIC) to localise the fault.
3	Low Output	Increase channel trims until CLIP just does not light on peaks; then raise MASTER. Confirm source is at line level (not headphone-low).
4	Distorted Sound	Watch CLIP LEDs; lower the hottest channel or source. Use correct input: mic → MIC; mixer/keyboard → LINE; guitar/bass (passive) → INSTRUMENT (Hi-Z). If distortion with no CLIP, reduce source output (hot feed).
5	Feedback (Howling)	Move microphones <b>behind the column axis</b> . Select <b>Speech</b> voicing for talk; reduce <b>SUB</b> for voice-only shows. Lower mic gains; increase distance between mic and column.
6	Bluetooth® Not Pairing / Unstable	Press & hold BT button ≈ 4 s to enter pairing (LED flashes). Clear the device's BT list and re-pair. Keep source within typical BT range; minimise RF congestion; avoid bodies/metal blocking line-of-sight. Use wired I/O for live monitoring (latency).
7	Hum or Noise	Use balanced <b>XLR/TRS</b> cables; avoid unbalanced TS on long runs. Separate audio from AC; cross at 90°. Try a different AC circuit; avoid sharing with lighting dimmers. If required, use an <b>audio isolation transformer</b> (do <b>not</b> lift mains earth).
8	Daisy-Chain: Next Unit Silent	Cable LINK OUT → MAIN IN (not MIC/LINE). On follower units set MIXER ENABLE = OUT; keep CH-1/2/3 at MIN. Walk the chain; repatch around any failed unit.

---

9	<b>Uneven Coverage</b>	Assemble full column height; keep vertical and central. Raise top above audience head height. Add a linked unit mid-room at lower <b>MASTER</b> for fill.
10	<b>Thermal Mute / Protection Limiting</b>	Improve airflow; keep vents clear ( $\geq 100$ mm). Reduce sustained output; allow cool-down. Avoid direct sun / enclosed niches; operate 0–35 °C.
11	<b>Mic Issues (Ribbon / Phantom / Handling)</b>	Avoid phantom on passive ribbons; use active ribbon or inline booster as specified. Use <b>MIC (90 Hz)</b> input to reduce handling/footfall rumble.
12	<b>Instrument Noisy / Thin</b>	Connect passive guitar/bass to <b>INSTRUMENT (Hi-Z)</b> , not <b>LINE</b> . Try a shorter, known-good instrument cable.

## Section 9: Specifications

Specifications are identical across the platform except where noted (10" vs 12" subwoofer). Values are nominal.

Item	Meline S30C (10")	Meline S50C (12")
Max SPL	117 dB peak (87dB continuous) @ 1 m	118dB peak (83 dB continuous) @ 1 m
Frequency Response (-10 dB)	48 Hz – 20 kHz	45 Hz – 20 kHz
Rated Power (peak)	1550 W total (LF 1250 W + MF/HF 300 W)	1550 W total (LF 1250 W + MF/HF 300 W)
High Driver	0.75" exit neodymium compression driver	0.75" exit neodymium compression driver
Mid Drivers	4 × 3" neodymium mid-range	4 × 3" neodymium mid-range
Subwoofer	10" neodymium woofer	12" neodymium woofer
Mixer / Inputs (on-board)	3-channel mixer, up to 7 inputs: Ch.1 Mic/Instrument; Ch.2 Mic/Line; Ch.3 3.5 mm AUX; Bluetooth® audio; XLR MAIN IN	Same
Outputs / Linking	XLR LINK OUT (balanced, +4 dBu)	Same
User Controls	CH-1/2/3 level with CLIP LEDs; MASTER level; SUB level; MODE selector (Concert/Club/Speech); MIXER ENABLE (IN/OUT); Bluetooth® pair (press & hold ≈4 s)	Same
Indicators	Ch.1/2/3 Clip; Master Activity; Mode (Concert/Club/Speech); Bluetooth® Status	Same
Dimensions — Sub (inches)	16D × 12.6W × 22H	16D × 12.6W × 23.9H
Dimensions — Sub (cm)	40.6D × 32W × 55.9H	40.6D × 32W × 60.7H
Dimensions — Extension Column (inches)	3.6D × 3.6W × 32.5H	3.6D × 3.6W × 32.5H
Dimensions — Extension Column (cm)	9.1D × 9.1W × 82.6H	9.1D × 9.1W × 82.6H
Dimensions — Speaker Column (inches)	3.6D × 3.6W × 32.8H	3.6D × 3.6W × 32.8H
Dimensions — Speaker Column (cm)	9.1D × 9.1W × 83.3H (approx.)	9.1D × 9.1W × 83.3H (approx.)

---

<b>Item</b>	<b>Meline S30C (10")</b>	<b>Meline S50C (12")</b>
<b>Assembled Height</b>	82.36" / 209.2 cm	82.83" / 210.4 cm
<b>Weight (system)</b>	40.57 lb / 18.4 kg	43.65 lb / 19.8 kg
<b>Construction</b>	Wood LF enclosure; ABS column; powder-coated metal grille	Same
<b>Voicings (DSP)</b>	Concert / Club / Speech presets	Same

*Bluetooth® word mark and logos are registered trademarks of Bluetooth SIG, Inc. All other trademarks are the property of their respective owners.*

# Meline S30C

## Frequency Response Curve

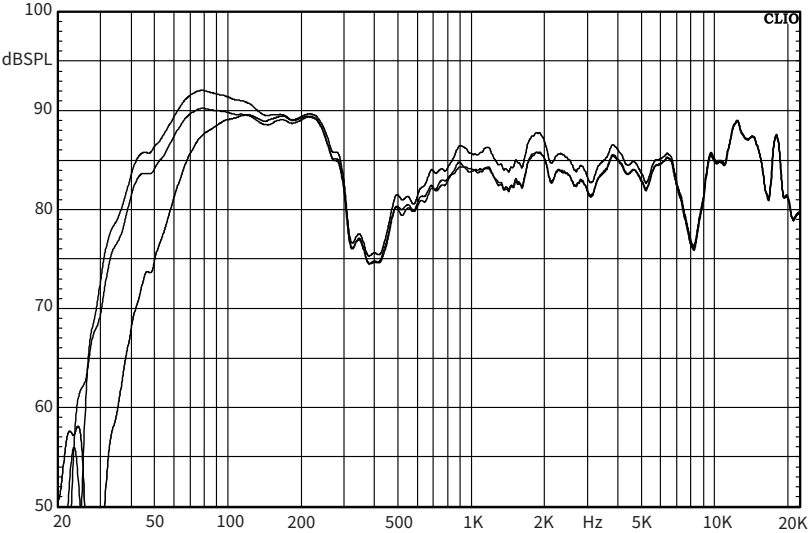

## Impedance Curve

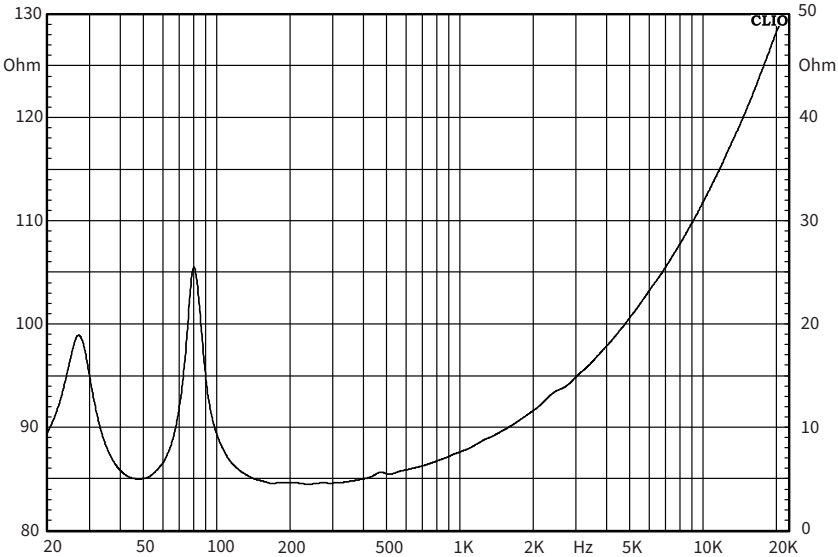

## 2D Dimension

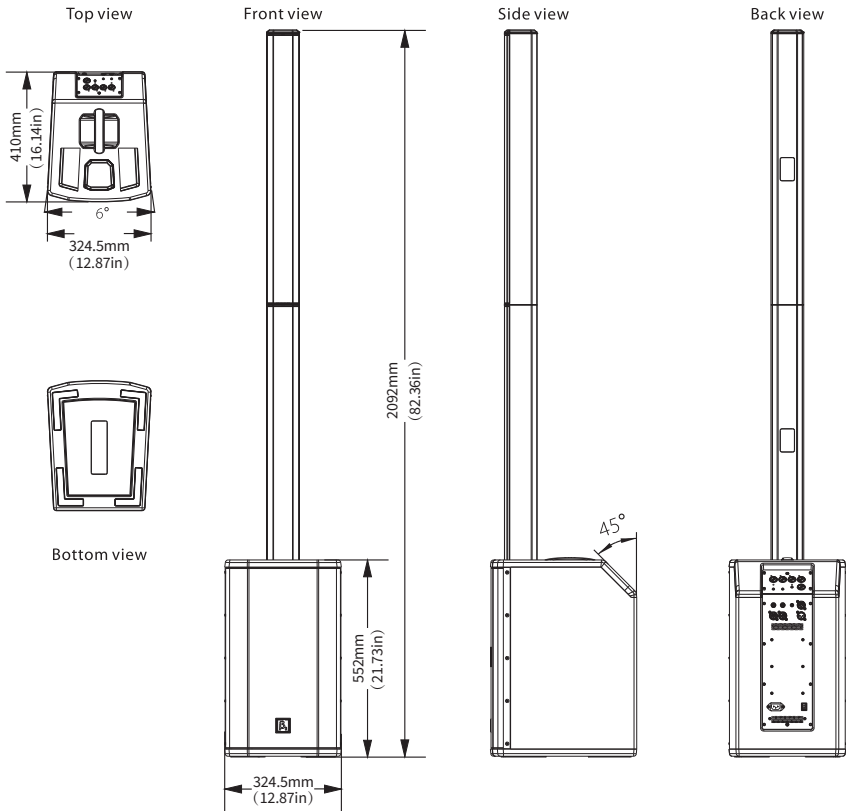

### Array Bar:

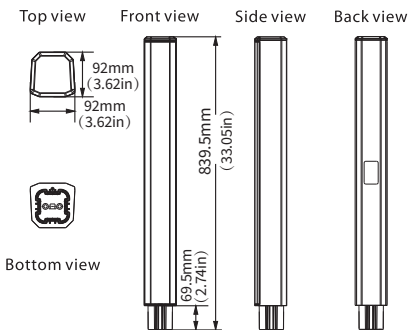

### Extension Bar:

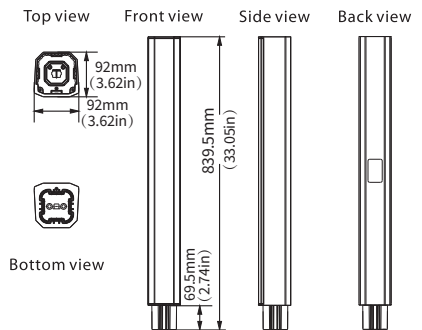

# Meline S50C

## Frequency Response Curve

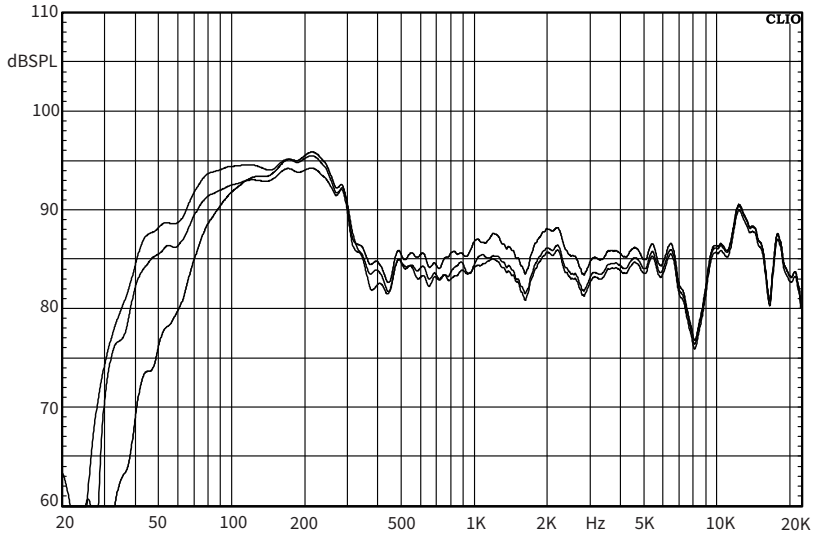

## Impedance Curve

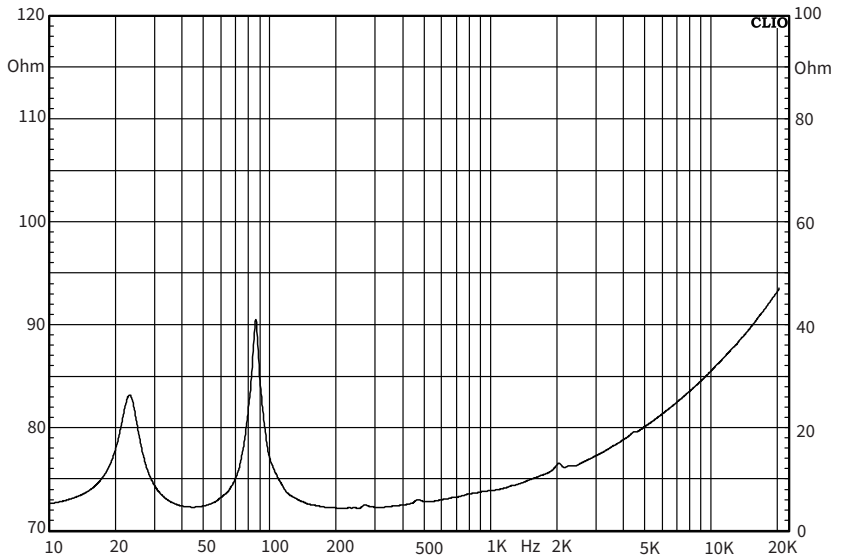

## 2D Dimension

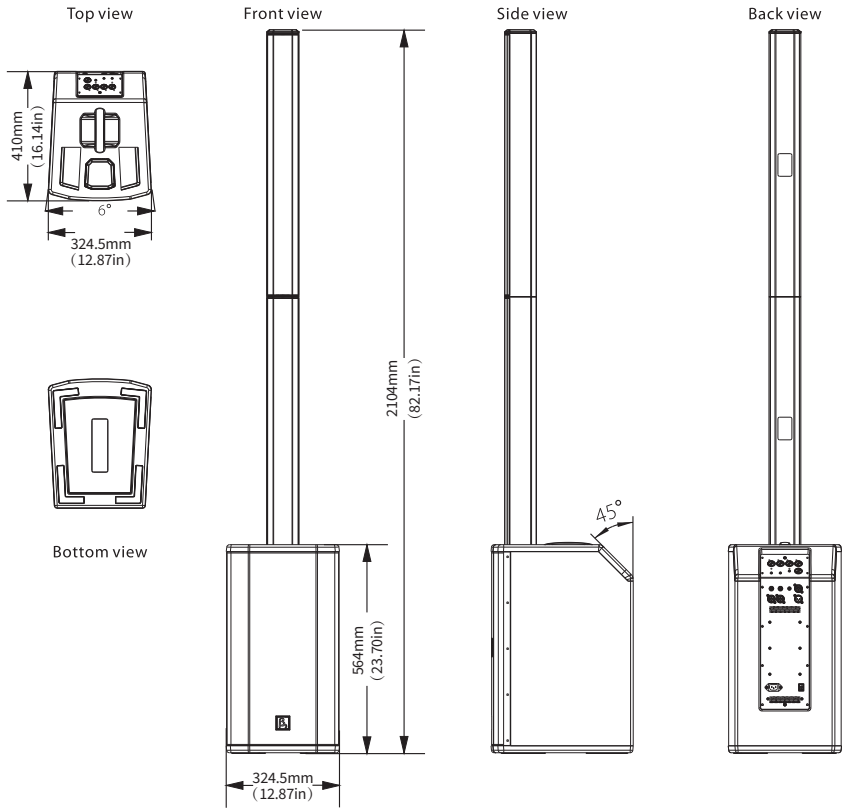

### Array Bar:

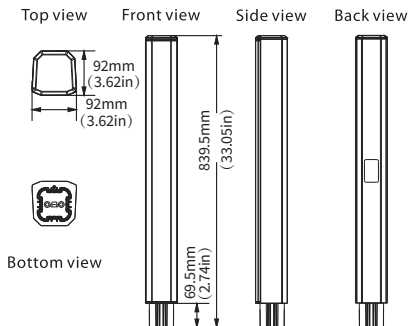

### Extension Bar:

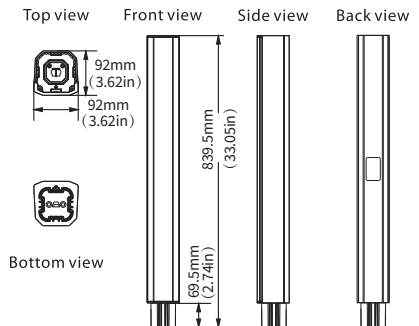



**Beta Three**

3G Audio Technology Co., Ltd.

No.1, 7th South Street, Qiaodong Road, Qiaotou Town, Dongguan City, Guangdong, China

Tel: +86-769-89061679 Fax: +86-769-89061670 Email: support@betathree.org

Website: www.beta3pro.com

Dongguan 3G Audio Technology Co., Ltd. reserves the right to alter design and specifications without notice.

All rights reserved © 2025 3G Audio Technology Co., Ltd.

BETA THREE® is a member of the 3G Audio Technology Co., Ltd.